

Flat type

Operating pressure 0 to 15 bar
 Operating temperature -10 °C to 250 °C
 Stainless steel alloy SS316
 Pore size: 40 to 50 µm

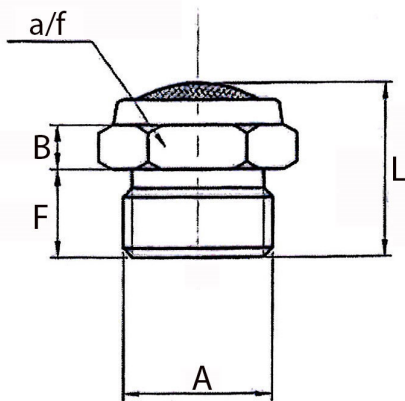

SD14ESFL

Silencer, stainless steel, flat type

Art. No.	Type No.	Thread A	F mm	B mm	a/f mm	L mm
156485	SD5ESFL	M5	5.0	3.0	8	11.5
156486	SD18ESFL	G 1/8	6.0	4.0	13	15.0
156487	SD14ESFL	G 1/4	8.0	4.8	16	19.0
156488	SD38ESFL	G 3/8	8.0	5.0	19	19.5
156489	SD12ESFL	G 1/2	10.0	5.0	24	22.0
156490	SD34ESFL	G 3/4	10.0	5.5	30	25.5
156491	SD1ESFL	G 1	11.5	6.0	36	27.0

Flow rates and Noise levels

Art. No.	Type No.	Flow rate l/min.	Noise level, reduced
156485	SD5ESFL	310	≥ 20 dB(A)
156486	SD18ESFL	560	≥ 20 dB(A)
156487	SD14ESFL	850	≥ 25 dB(A)
156488	SD38ESFL	1200	≥ 25 dB(A)
156489	SD12ESFL	2050	≥ 20 dB(A)
156490	SD34ESFL	4200	≥ 15 dB(A)
156491	SD1ESFL	5340	≥ 15 dB(A)

- The use of silencers does not automatically reduce exhaust noise to a safe level.
The need for other noise-reducing measures, such as hearing protection, must be assessed as well.

- Uses and applications are the responsibility of the user. However, it is necessary to carry out appropriate tests before use in order to convince yourself of the desired function under the respective conditions.
All further claims, in particular liability for consequential damages, are excluded in principle.

Non-binding standard values, depending on the application and adaptation. The suitability test for the respective application is the responsibility of the user.